

Commercial Applications



CASE STUDY L.A. City Hall East

Project field: Cooling tower water treatment
Project Start Date: 2018



SUMMARY

COOLING TOWER SYSTEM

Air Conditioning system of the main building

UET REACTOR SIZING

2X(1X8) UET-STD Reactors

MAKE UP SOURCE

100% Tap Water



The UET unit treating cooling towers on site

IMPACT

UET partnered to bring this chemical-free cooling tower water treatment system to the United States. The technology is designed to provide a high level of water treatment without the use of cooling tower chemicals. Accordingly, the system maintains a dynamic water equilibrium that manages scale, minimizes corrosion, and controls biological growth, which leads to reduced water discharge (blowdown) and overall water consumption, lower maintenance costs, and energy savings due to cleaner heat exchanger surfaces. The process removes scale from the water in a reactor instead of relying on blowdown to eliminate minerals. The technology uses a carefully controlled electrolysis process to split water into H⁺ and OH⁻ ions inside the reactor. The high concentration of OH⁻ ions at the cathode lowers the pH and leads to a high concentration of CO₃⁻² (bicarbonate ions), which accelerates the precipitation of hard minerals and silica inside the reactor instead of on tower surfaces and in the heat exchanger tubes. The system also maintains a dynamic equilibrium between the pH and alkalinity to minimize corrosion. Additionally, the system activates the chloride naturally present in the water, creating chlorine, which acts as a biocide. The result is a system that drastically increases the cycles of concentration and minimizes the blowdown, thereby saving water. The control of the scale results in cleaner heat transfer surfaces and reduced energy consumption. Cleaner water also creates a more reliable system that should also have longer overall equipment life. The system is installed to treat a side stream taken from the condenser water line leaving the cooling tower and returned to the cooling tower basin after treatment. A schematic of a typical installation is shown in Figure 2. Maintenance consists of monthly system inspection, cleaning scale from the reactor cores quarterly, and replacing the titanium reactor anode every 2–5 years.

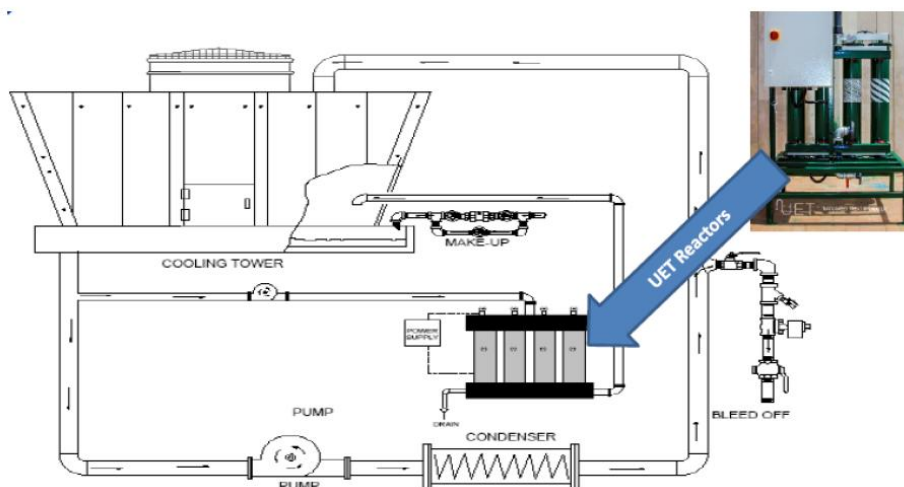

Figure 2. UET system schematic.